

# HotSense™ Field Data Logging Kit (FDLK) for automated ultrasonic measurement logging

For the rapid deployment and management of WirelessHART ultrasonic projects and data collection.

Ready to deploy data collection, node control and remote access solution for HotSense™ WirelessHART sensors. Deploy ultrasonic monitoring systems to industrial sites or remote sites without the need for integration into local IT networks

**Keywords:** corrosion, erosion, in-service monitoring, hazardous environments, ultrasonics, high-temperature, radiation



## HOTSENSE™ FIELD DATA LOGGING KIT (FDLK)

- **Self-contained and ready to deploy** HotSense™ WirelessHART Network.
- **Pre-configured data collection server** to log data from and manage HotSense™ Wireless Automated monitoring nodes.
- **No integration to site IT network required.** Fully independent and secure.
- **Reduce time** in project planning, preparation and implementation with a plug-and-play solution.
- **Moveable and portable** storage for deployment inside with rugged antenna for outdoor installation.
- **Data collected and stored on site** - no cloud connection required
- **Secure remote connection** option for data access and support.
- **Option to integrate into plant** data networks when ready.

## APPLICATIONS

- Support the safe processing of new feedstocks or monitor the impact of changing processing conditions on asset integrity operating windows (IOWs).
- Enable trending of asset integrity data to guide decision making, maximise plant availability and enable predictive maintenance.
- Identify the causes of your most troubling asset integrity challenges with high frequency, high precision trending data.
- Rapidly deploy automated UT monitoring with no IT network integration.
- Ideal for rapid installations, temporary monitoring projects and trials.

## FEATURES

Pre-configured data servers with:

- Automated data collection
- Measurement and wall loss trending
- Waveform collection
- Manual and automated data export
- Complete HotSense™ CALIPERAY remote management

hotsense<sup>ll</sup>® | Powered by ionix



# HotSense™ FDLK



VISIT US

## SPECIFICATION

CONTENTS	
Gateway	WirelessHART Gateway
Antenna	10m external antenna with pole mount
Data Server	On-site. Rugged industrial PC running Windows
Data Collection and Management	HotSense™ WAMP software pre-installed
Device Commissioning	WirelessHART configuration software pre-installed
Device Maintenance	HART USB Modem for device commissioning
Case	Rugged, portable, Peli-type case for deployment inside, vented
Power Supply	External power supply for local AC supply
Maximum number of WirelessHART Nodes Per Kit	= 25 (100 by request)
Ex Rating	None. Optional Ex rated external antenna with barriers
OPTIONS	
Remote Access	Outdoor LTE modem and router for global deployments
Data Contract	Local Fixed IP Public SIM
Outdoor Deployment	Rugged outdoor cabinet, IP55, with pole mounting hardware
Outdoor Power Supply	Rugged AC -> DC power supply for deployment outside

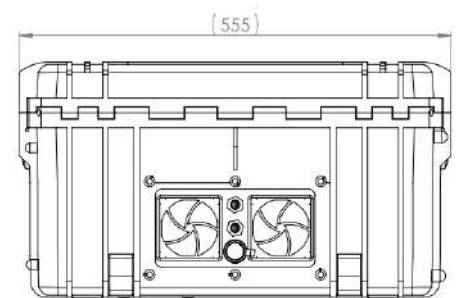
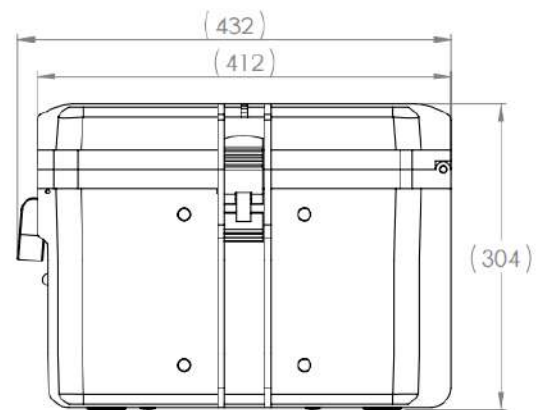
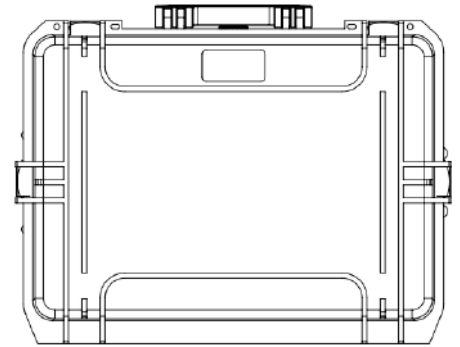

Dimensions shown in mm

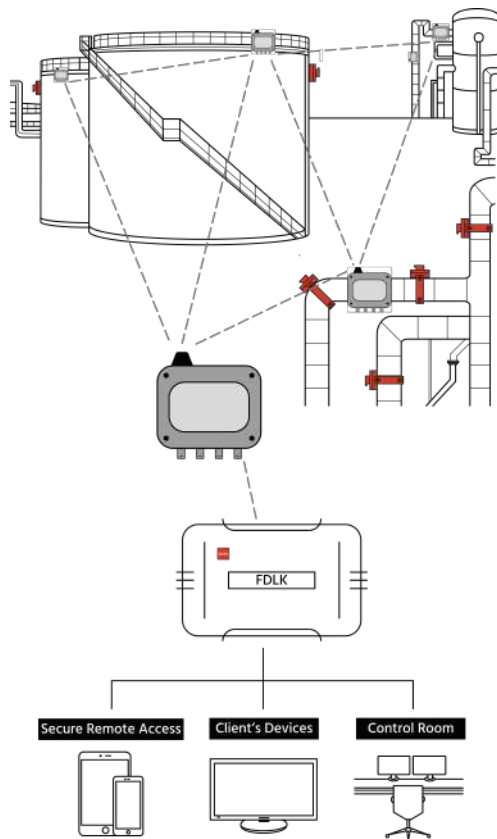

Get in touch for consultation:

0430 041 643

info@snintegrity.com.au

snintegrity.com.au

Follow us on LinkedIn:



VISIT US