



Seeing Is Retrieving!

JAWS 2.0™ is a rugged, motorized retrieval tool with integral Hi-Def camera and LED Lighting. It is easy to use, robust, submersible, and works in any industrial environment. JAWS 2.0 is available as a basic kit or as part of an ultimate loose-parts retrieval kit.

robust

aircraft-grade aluminum body • stainless steel jaws • halogen-free polyurethane cable jacket

compact

fits through 1.5" (38mm) openings • fits through 4" (100mm) diameter elbows

capable

jaws open 2.75" (70mm) • tool submerges to 100' (30m) • system deploys anywhere on batteries (12 Vdc, 15W NiMH)

Variety of interchangeable end-effectors

Compact design accesses the most remote areas

4 to 6 hour battery with power-save; recharges in 2 hours.

5" (127 mm) Industrial-grade 1080p HD (1920x1080 pixel) color display is sunlight-readable with hardened glass face

HDMI output allows recording and/or auxiliary display

Joystick operation is simple, easy to use

Controller measures 9 × 5.5 × 2.4" (229×138×61mm), weighs 3.1 lb (1.4 Kg)

With three ¼"-20 mounting points, controller mounts to wrist lanyard, neck lanyard, or tripod

Radiation Life Expectancy of 30,000 RAD (avg. total dose)

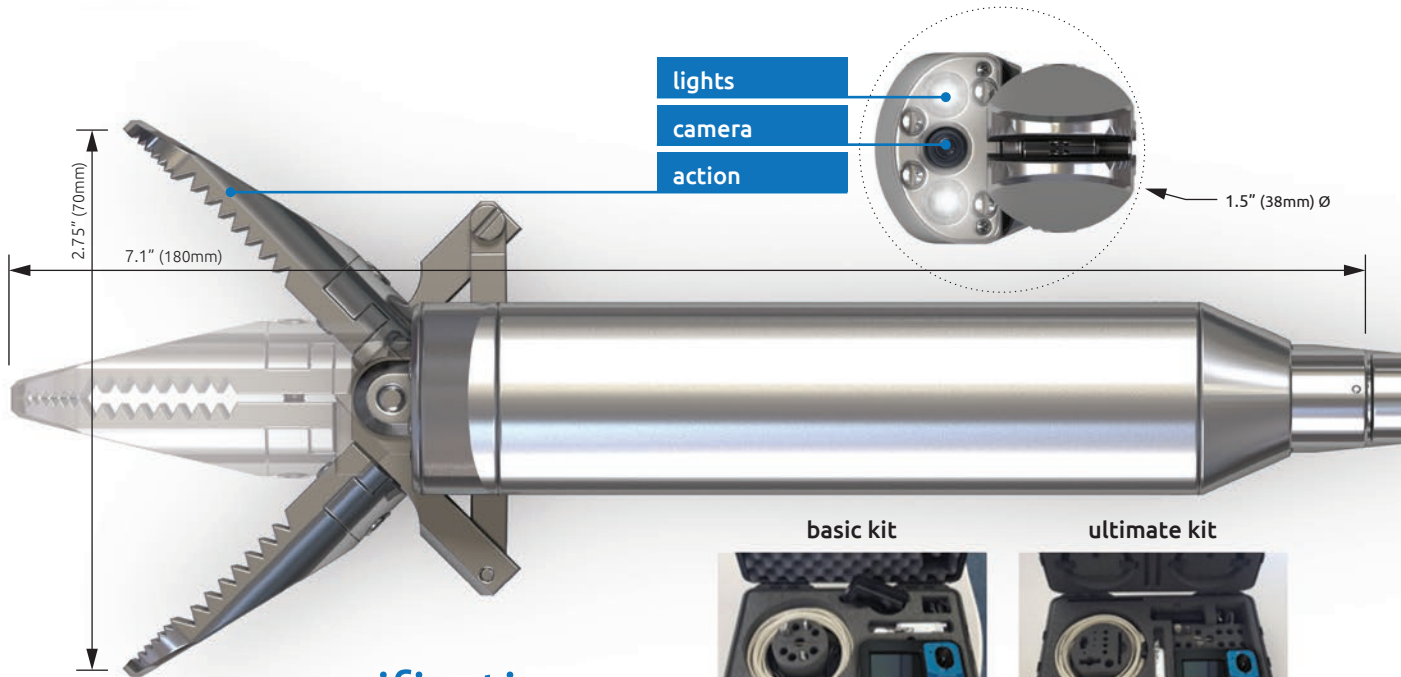

specifications



JAWS 2.0 can find and retrieve almost any dropped object!

standard components	<ul style="list-style-type: none"> • JAWS 2.0 HD grabber • JAWS 2.0 HD display/controller • AC adapter/charger • qty. 1 controller battery • operator manual • 50' (15m) power/video cable 	<ul style="list-style-type: none"> • JAWS 2.0 HD grabber • JAWS 2.0 HD display/controller • AC adapter/charger • qty. 2 controller batteries • operator manual • 50' (15m) power/video cable + 50' (15m) extension cable
case	14x22x8", 12 lb (5.5kg)	15½x25x8½", 19 lb (8.6kg)
jaws	short serrated jaws (others may be ordered separately)	fork and tine • flat serrated jaws short serrated jaws • sampling cups curved serrated jaws • tool adapter needle-nose jaws
tools		qty. 2 (two) snares: sm, lg qty. 2 (two) magnets: sm, lg (w/ case) qty. 4 (four) hooks: sm, med, lg, xl
push poles		qty. 10 (ten): 5'x³/16"Ø (1.5m x 6mmØ) qty. 10 (ten): 5'x¹/4"Ø (1.5m x 6mmØ) qty. 10 (ten): 5'x³/16"Ø (1.5m x 8mmØ) qty. 10 (ten): 5'x³/8"Ø (1.5m x 9mmØ) qty. 1 (one): 6'x³/16"Ø (150mm x 8mmØ) qty. 1 (one): 12'x³/16"Ø (300mm x 8mmØ) qty. 1 (one): 16'x³/16"Ø (405mm x 5mmØ) qty. 1 (one): 16'x¹/4"Ø (405mm x 6mmØ) qty. 1 (one): 16'x³/16"Ø (405mm x 8mmØ) qty. 1 (one): 16'x³/8"Ø (405mm x 9mmØ)
push pole accessories		quiver • tee handle • adjustable elbow rubber flex joint • spring flex joint
misc.		hex keys, screws, hoist lifting ring

